



# **HORIZON DC** **INFRAESTRUCTURA** **PARA DATA CENTER**

## **CATÁLOGO DE PRODUCTOS**

HORIZON, suministros especializados para la habilitación de Data Center. Los productos HORIZON cumplen estrictamente con normas internacionales y cuentan con certificados de calidad y respeto al medio ambiente.



**GABINETES**

---

**UPS**

---

**COOLING**

---

**PDU**

---

**AIRE ACONDICIONADO  
DE PRECISIÓN**

---

**PISO TÉCNICO**

---

**BANDEJAS**

**HORIZON LATAM**

[Info@horizonlatam.com](mailto:Info@horizonlatam.com)

# GABINETE PROFESIONAL PARA REDES Y SERVIDORES

## SNB SERIES

- Soporta hasta 800 Kg
- Puertas laterales desmontables
- Cobertor superior para entrada de cables
- Puerta frontal de vidrio o microperforada
- Niveladores
- Ruedas de desplazamiento (2 con freno)
- Ordenador de cable vertical en la parte posterior
- Cerradura avanzada
- Pintura de protección

1. Cubierta superior
2. Base inferior
3. Marco de Puerta
4. Puerta frontal
5. Puerta posterior
6. Panel lateral
7. Barra horizontal lateral
8. Riel vertical
9. Riel ordenador vertical (solo 800mm de ancho)
10. Cuadro conector
11. Ruedas
12. Tornillo Nivelador

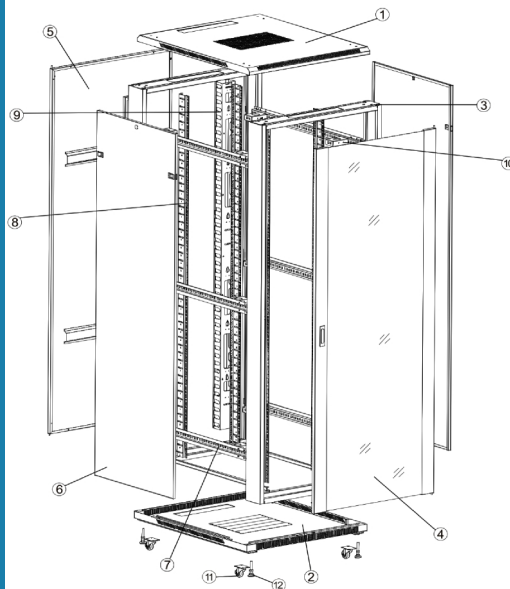

# SNB SERIES STANDING NETWORK RACK

27U, 32U, 42U and 47U Sizes



Puertas desmontables con chapa de seguridad



Tapa superior perforada para uso de extractores



Parantes estructurables móviles



Estructura de fácil ensamblaje

### Colores



Modelo	Capacidad RU	Dimensiones
SNB6622	22	600X600X1166
SNB6822	22	600X800X1166
SNB6637	37	600X600X1833
SNB6837	37	600X800X1833
SNB6137	37	600X1000X1833
SNB6642	42	600X600X2055
SNB6842	42	600X800X2055
SNB8842	42	800X800X2055
SNB6142	42	600X1000X2055
SNB8142	42	800X1000X2055

### Opciones de puerta frontal

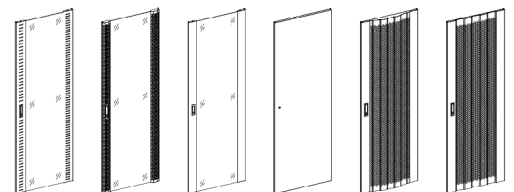

# HORIZON



# SSN SERIES

## NINE-FOLDED PROFILED SERVER RACK

### GABINETE PROFESIONAL PARA REDES Y SERVIDORES

#### SSN SERIES

- Soporta 1500 Kg
- Puertas laterales desmontables
- Cobertor superior para entrada de cables
- Puerta frontal perforada (78%) y curva
- Puerta posterior doble y perforada (78%)
- Niveladores
- Ruedas de desplazamiento (2 con freno)
- Ordenador de cable vertical en la parte posterior
- Cerradura avanzada
- Pintura de protección

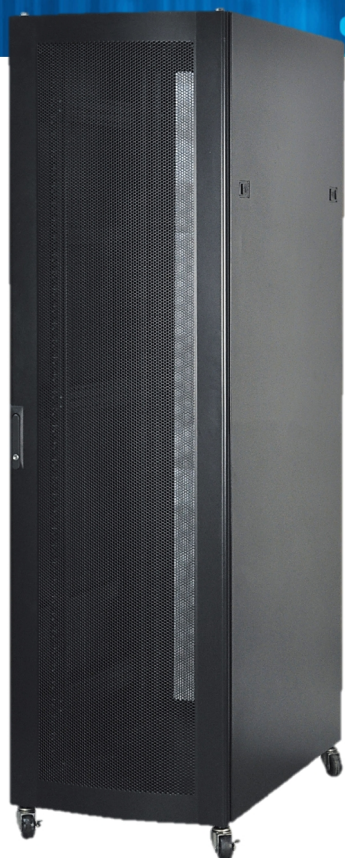

Estructura principal con 9 dobleces de seguridad



Opción de puerta lateral superior e inferior

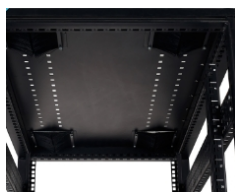

Panel superior con orificios para el pase de cables



Puerta frontal perforada y torneada

#### Colores

RAL9005

RAL7035

Modelo	Capacidad RU	Dimensiones
SSN6842	42	600X800X2000
SSN6642	42	600X600X2000
SSN6142	42	600X1000X2000
SSN8142	42	800X1000X2000
SSN6847	47	600X800X2225
SSN6647	47	600X600X2225
SSN6147	47	600X1000X2225
SSN8847	47	800X800X2225
SSN8147	47	800X1000X2225

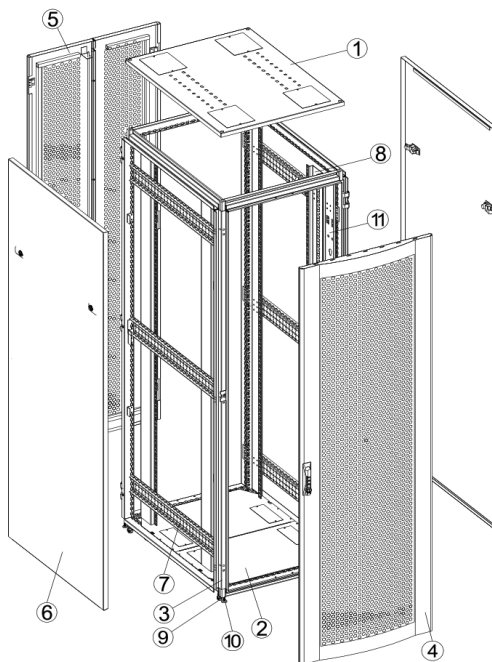

1. Cubierta superior
2. Base inferior
3. Marco de puerta
4. Puerta frontal curva
5. Puerta posterior doble
6. Puerta lateral
7. Barra horizontal perforada
8. Riel vertical
9. Ruedas
10. Tronillo nivelador
11. Riel ordenador vertical (solo en 800mm de ancho)

# GABINETE PROFESIONAL DE PARED

# SMB SERIES DOUBLE SECTION WALL MOUNTED CABINET

## SNB SERIES

- Soporta hasta 60 Kg
- Puertas laterales desmontables
- Panel superior con orificios para ventiladores
- Puerta frontal de vidrio o microperforada
- Marco posterior con apertura basculante
- Orificios de anclaje a pared
- Fácil ensamble



Puertas desmontables con chapa de seguridad



Acceso posterior con marco de apertura lateral



Panel superior con orificio para la instalación de ventiladores



1. Marco
2. Bracket horizontal
3. Riel vertical
4. Panel superior
5. Puerta frontal
6. Puerta posterior
7. Marco posterior basculante
8. Panel lateral
9. Soporte en L

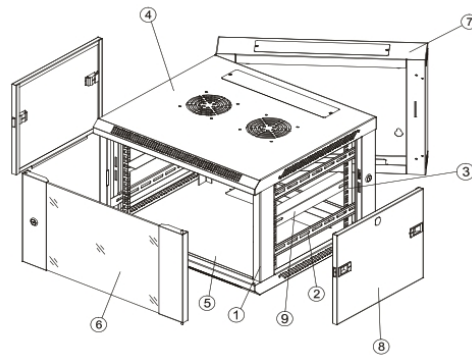

Modelo	Capacidad RU	Dimensiones
SMB6506	6	600X550X370
SMB6606	6	600X600X370
SMB6509	9	600X550X500
SMB6609	9	600X550X500
SMB6512	12	600X550X635
SMB6612	12	600X600X635
SMB6515	15	600X550X770
SMB6615	15	600X600X770
SMB6518	18	600X550X900
SMB6618	18	600X600X900

### Opciones de puerta frontal

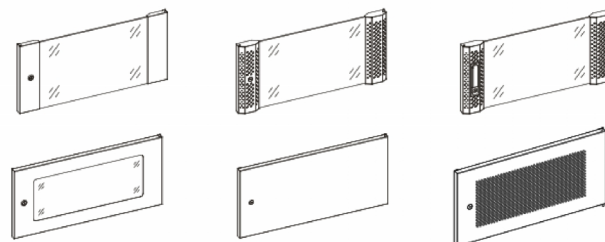

# RACK accesorios



## Ordenador Plástico frontal

- Ordenador de un lado
- Plastico negro RAL9005
- Horizontal 19"

SWFPCABLEDUCT1U 483x85x48  
SWFPCABLEDUCT2U 483x85x92

## Ordenador Plástico frontal / posterior

- Ordenador de doble lado
- Plastico negro RAL9005
- Horizontal 19"

SWFPCABLEDUCT1U 483x175x48  
SWFPCABLEDUCT1U 483x175x92



## Ordenador de anillos

- Ordenador de anillos.
- Plastico negro y SPCC RAL9005.
- Horizontal 19".

SWPCABLERING1U 483x42x80  
SWPCABLERING2U 483x88x80

## Ordenador vertical Plástico

- Ordenador vertical simple.
- Plastico negro RAL9005.
- Horizontal 19".

SWPCABLEDUCT1UVRT 45x70x860  
SWPCABLEDUCT2UVRT 88x70x860



## Ordenador vertical

- Ordenador vertical para gabinete SNB.
- Plastico negro RAL9005.
- Horizontal 19".

SWCABLEMNVRT37-SNB 37 U  
SWCABLEMNVRT42-SNB 42 U

## Bandeja de ventilador SNB

- 2 a 4 ventiladores.
- Metal negro RAL9005.

SWSNBFANTRAY2-600 346x412x40  
SWSNBFANTRAY4-800 546x412x40  
SWSNBFANTRAY4-1000 746x412x40



## Bandeja fija 4 puntos

- 4 orejas ajustables de montaje 19".
- Acero negro RAL9005.
- Capacidad de 120Kg.

SWAFSHELF-350 483x350x43  
SWAFSHELF-550 483x550x43  
SWAFSHELF-650 483x650x43

## Bandeja fija 2 puntos

- 2 orejas ajustables de montaje.
- Acero negro RAL9005.
- Capacidad de 20Kg.

SW2P1USHELF-300 483x300x43  
SW2P1USHELF-350 483x350x43  
SW2P1USHELF-300 483x300x88



## Panel ciego de metal

- Panel de 1U a 4U de metal.
- Bloquea el pase de aire forzandolo a enfriar los equipos.
- Acero negro RAL9005

SWM1UPANEL 483x42x10  
SWM2UPANEL 483x88x10  
SWM4UPANEL 483x175x10

## Panel con escobillas

- Panel de 1U a 4U de metal.
- Bloquea el pase de aire forzandolo a enfriar los

SW1UBRUSHPANEL 483x42x15



## Panel de iluminación

- Panel para iluminación
- 19" estandar
- Lámpara de 8w

SWLIGHTPANEL8W 483x44x60

## Power rack

- Panel horizontal 19"
- 8 -12 puertos.
- Switch master on/off
- Circuit breaker (optional)
- RoHS
- Cable 2mt x 1.5mm2

SW-1U-V8 1 U  
SW-1U-V10 1 U  
SW-1U-V12 1 U

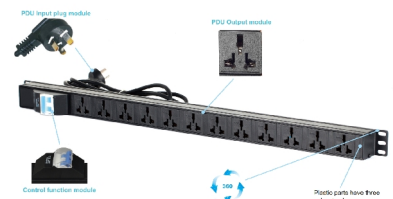



# AISLE Containment

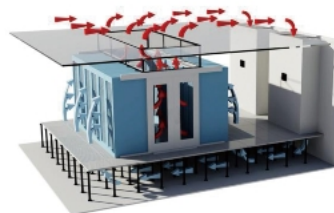

Hot aisle containment

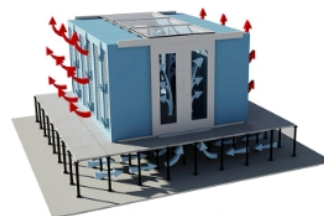

Cold aisle Containment



Modelo	Descripción
SSG6142KIT	Incluye 2 gabinetes SSG6142, 1 ventana superior
SSG8142KIT	Incluye 2 gabinetes SSG8142, 1 ventana superior



Modelo	Descripción
TC-0612AG	Incluye ventana rotativa y perfil decorativo
TC-0612GD	Incluye ventana fija y perfil decorativo



Modelo	Descripción
SWMCABLETRAY600	Bandeja eléctrica para rack de 600mm
SWMCABLETRAY800	Bandeja eléctrica para rack de 800mm
SWNCABLETRAY600	Bandeja de data para rack de 600mm
SWNCABLETRAY800	Bandeja de data para rack de 800mm

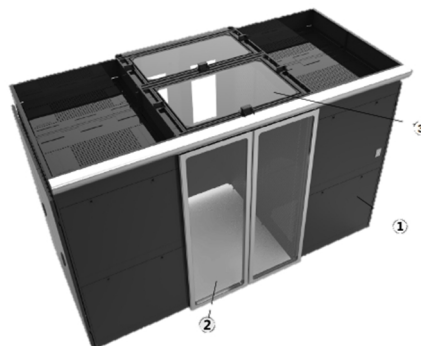

## AISLAMIENTO DE PASILLOS FRIO Y CALIENTE

### SOLUCIÓN DE AISLAMIENTO TÉRMICO

- 100% modular
- Puertas de ingreso, mecánica, semiautomática y automática
- Cobertor de ventana pivotante con apertura mecánica o automática
- Compatible con sistemas de control de acceso
- Elegante estructura superior
- Rieles superiores para el ordenamiento de cableado
- Diseño con apertura doble o simple
- Compatible con Gabinetes de la serie SSN
- Iluminación de pasillo

1. Gabinete
2. Puerta deslizable
3. Ventana Superior



# SMART PDU

## PDU SERIES

- Diversos tipos de conectores de entrada.
- Medición de corriente/voltajes de salidas.
- Sensores ambientales de temperatura y humedad.
- Alarmas y notificaciones via email, SNMP and SYSLOG.
- Puertos de monitoreo Ethernet & consola de administración CLI
- Upgrade de software sin reinicio del sistema.

1. Smart PDU pre-configurados
2. Diseño a medida en proyectos especiales
3. Puertos y entradas compatibles
4. Administración remota
5. Montaje horizontal y vertical
6. APP para monitoreo
7. Monitoreo ambiental
8. Panel LCD
9. Botones de navegación

# PDU series

## Opción de outlet

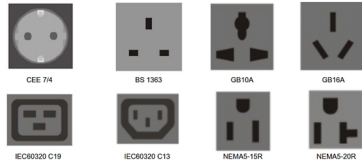

## Conectores de entrada



Especificaciones SW-M-8IECC13			
Input Connector	IEC-320-C20, 16A connector	Sensor Interface	(1)RJ11
Output Connector	(8) IEC 320 C13	Console Interface	(1)RJ45
Sensor Interface	(1) RJ11		
Ethernet Interface	(1)RJ45		



Especificaciones SW-M-B27IECC13			
Input Connector	L6-30P, 30A connector	Console Interface	(1)RJ45
Output Connector	(18) IEC-320-C13+(6) C19	RS485 Interface	(2)RJ45
Sensor Interface	(3)RJ11	ExT Interface	(1)RJ45
Ethernet Interface	(1)RJ45	Display	LCD

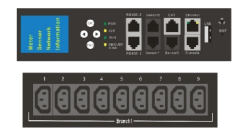

Especificaciones SW-M-B27IECC13			
Input Connector	L21-30P, 30A connector	Console Interface	(1)RJ45
Output Connector	(27) IEC-320-C13	RS485 Interface	(2)RJ45
Sensor Interface	(3)RJ11	ExT Interface	(1)RJ45
Ethernet Interface	(1)RJ45	Display	LCD



Especificaciones SW-M-B27IECC13			
Input Connector	IEC-309,P+N+E,32A connec.	Console Interface	(1)RJ45
Output Connector	(16)IEC-320-C13+(4) C19	RS485 Interface	(2)RJ45
Sensor Interface	(3)RJ11	Display	LCD
Ethernet Interface	(1)RJ45		

